

Site Selection and Design for LNG Ports and Jetties



Information Paper No. 14

SIGTTO

Site Selection and Design for LNG Ports and Jetties

*with views on
RISK LIMITATION during PORT NAVIGATION
and CARGO OPERATIONS*

Information Paper No. 14

*Published in 1997 by
© Society of International Gas Tanker and Terminal Operators Ltd*

*Designed & Printed by Worldwide Marine Technology
The Court House, 15 Glynne Way, Hawarden, Deeside, Flintshire, CH5 3NS, Wales, United Kingdom
Tel: +44 (0) 1244 535787 Fax: +44 (0) 1244 538908 E-mail: sales@wmtmarine.com*

*Distributed by Witherby & Co Ltd
32-36 Aylesbury Street, London EC1R 0ET
Telephone: +44 (0) 171 253 5413 Fax: +44 (0) 171 251 1296*

ISBN: 1 85609 129 5

*1st Edition - January 1997
Reprinted - August 2000*

Cover photograph - Ras Laffan LNG port.

Notice of Terms of Use

While the information given in this document has been developed using the best advice available at the time of publication, it is intended purely as guidance to be used at the owner's risk. No responsibility is accepted by the Society of International Gas Tanker and Terminal Operators Ltd, or by any person, firm, corporation or organisation who, or which, has been in any way concerned with the furnishing of information or data, the compilation, publication or authorised translation, for the accuracy of any information or advice given herein or for any omission herefrom or for any consequences whatsoever resulting directly or indirectly from the compliance with or adoption of guidance contained herein even if caused by a failure to exercise reasonable care.

Contents

	Page No.
Nomenclature	1
1 Summary	2
2 Principal Recommendations	3
2.1 Port Design	3
2.2 The Jetty	3
3 Acknowledgments	4
4 Introduction	4
5 Development of LNG Standards	5
6 Site Selection	6
6.1 General	6
6.2 Jetty Location	6
7 Design Criteria for Jetties	7
7.1 Root Criteria for Hazardous Liquid Cargoes	7
7.2 Specific Criteria for LNG	8
8 Risk Management in the Port Approach	13
8.1 Port Controls	13
9 The Human Element	15
10 Grounding and Collision Risk	16
10.1 Hull Damage - a Historical Review	17
10.2 Risk of Structural Damage to LNG Carriers	17
10.3 Examples	19
11 References	21
Appendix	23

NOMENCLATURE

BSI	British Standards Institute
CEN	Comité Européen de Normalisation
ESD	Emergency Shut-Down
ERS	Emergency Release System; a system comprising all ESD and PERC measures
IALA	International Association of Lighthouse Authorities
IAPH	International Association of Ports and Harbors
ICS	International Chamber of Shipping
ISGOTT	International Safety Guide for Oil Tankers and Terminals
LNG	Liquefied Natural Gas
LPG	Liquefied Petroleum Gas (butane and propane)
OCIMF	Oil Companies International Marine Forum
PERC	Powered Emergency Release Coupler, with its adjacent quick-acting block valves. This is a device providing a virtual spill-free means of quick disconnection of the hard arm in emergency situations. The block valves are interlocked with the coupler to ensure dual action.
PIANC	Permanent International Association of Navigation Congresses
SIGTTO	Society of International Gas Tankers and Terminal Operators Ltd
TSS	Traffic Separation Scheme
VTS	Vessel Traffic Services

1 SUMMARY

This paper addresses safety issues for LNG ports. It focuses on the elimination of spillages both at the ship/shore interface and in navigational approach channels. The paper concentrates on issues which can be solved when a port is being designed and is, therefore, of benefit to harbour planners and port authorities. Flowing from these considerations, the paper outlines a way forward for the site selection of LNG terminals, establishes a basis for safe jetty design and considers safety factors in the port approach. In developing its first aim, the paper examines existing industry guidelines covering cargo operations at the ship/shore interface. Indeed, the paper suggests that LNG's excellent safety record owes much to the adoption of existing standards. However, with the industry becoming more widespread, as a second aim, continuing success depends not only on better acceptance of existing standards but also on future improvements. Some of these newer aspects are described and a check list is presented in the Appendix giving an overall package of the items considered most essential for LNG.

Bearing in mind the high commercial exposures within LNG projects, the need to maintain its good safety record is vital to all companies concerned. Furthermore, an incident in one port could have serious knock-on effects in others, and may herald constraints in new projects elsewhere. These concerns, coupled with the dangers perceived during public inquiries into LNG transport, make a very strong case indeed for a continuing high level of safety to be applied.

On ships the good safety record for LNG operations is predicated on an excellent standard of management, high quality crews, the structural robustness of ships' hulls and back-up control systems. On shore, also of importance, are the select number of well managed terminals. At these plants the focus of national agencies, port authorities and terminal managers ensure that safety in operations is always an important element.

However, although LNG has an enviable record it is not risk free. Not only are some hazards difficult to eradicate; an accident, albeit rare, is possible as a result of human error or catastrophic event such as an earthquake. Moreover, technical limitations can have an effect and site location may not always achieve a port design which is entirely risk-free. It can be seen, therefore, that there can remain a very remote chance for some incidents to occur. However, a large release of LNG such as through a damaged hard arm or a ruptured cargo containment system — central themes in this paper — should be specially addressed during port design.

Important matters which should be dealt with when choosing the location of a new terminal are covered in the paper. Apart from general considerations, these emphasis the need for the introduction of risk management techniques. A fact which helps to ease the acceptance of these newer concepts in the LNG trade is its relatively close-knit nature and because most of the trade is held by only a few companies within well-defined limits. Also, investments in LNG projects are such that equipment quality can be planned to a high standard.

This paper proposes the adoption of the recommendations outlined in chapter 2. However, criteria such as that for channel width, should not be understood as absolute values; these recommendations are just basic guides to prompt special enquiry into particular aspects. Furthermore, the actual values quoted together with their risk reduction effect, still depend on local conditions which have to be covered individually, port by port.

2 PRINCIPAL RECOMMENDATIONS

2.1 PORT DESIGN

Approach Channels. Harbour channels should be of uniform cross-sectional depth and have a minimum width, equal to five times the beam of the largest ship.

Turning Circles. Turning circles should have a minimum diameter of twice the overall length of the largest ship, where current effect is minimal. Where turning circles are located in areas of current, diameters should be increased by the anticipated drift.

Tug Power. Available tug power, expressed in terms of effective bollard pull, should be sufficient to overcome the maximum wind force generated on the largest ship using the terminal, under the maximum wind speed permitted for harbour manoeuvres and with the LNG carrier's engines out of action.

Traffic Control. A Vessel Traffic Service (VTS) System should be a port requirement and this should be able to monitor and direct the movement of all ships coming within the operating area of LNG carriers.

Operating Limits. Operating criteria, for maximum wind speed, wave height, and current, should be established for each terminal and port approach. Such limits should match LNG carrier size, manoeuvring constraints, and tug power.

Speed Limits. Speed limits should be set for areas in the port approach presenting either collision or grounding risks. These limits should apply not only to LNG carriers but also to any surrounding traffic.

2.2 THE JETTY

Exclusion of Ignition Sources. No uncontrolled ignition source should be within a predetermined safe area centred on the LNG carrier's cargo manifold.

Mooring Layout. The terminal should provide mooring points of a strength and in an array which permits all LNG carriers using the terminal to be held alongside in all conditions of wind and current.

Quick Release Hooks. All mooring points should be equipped with quick release hooks. Multiple hook assemblies should be provided at those points where multiple moorings lines are deployed so that not more than one mooring line is attached to a single hook.

Emergency Release System. At each hard arm the terminal should fit an ERS system, able to be interlinked to the ship's ESD system. This system must operate in two stages: the first stage stops LNG pumping and closes block valves in the pipelines; the second stage entails automatic activation of the dry-break coupling at the PERC together with its quick-acting flanking valves. The ERS System should conform to an accepted industry standard [15].

Powered Emergency Release Couplers (PERCs). The terminal should fit a PERC in each hard arm together with quick-acting flanking valves so that a dry-break release can be achieved in emergency situations.

Terminal Security. An effective security regime should be in place to enforce the designated ignition exclusion zone and prevent unauthorised entry into the terminal and jetty area, whether by land or by sea.

Operating Limits. Operating criteria, expressed in terms of wind speed, wave height, and current, should be established for each jetty. Such limits should be developed according to ship size, mooring restraint, and hard arm limits. Separate sets of limits should be established for (a) berthing, (b) stopping cargo transfer, (c) hard arm disconnection and (d) departure from the berth.

3 ACKNOWLEDGMENTS

The content of this paper is based on reports from a company having SIGTTO membership and, in this respect references [1] and [2] were most valuable. The navigational aspects, as detailed in chapters 9 and 10, came about as personnel in that company assessed marine operational risks for new LNG terminals. In one case, the new project was in Europe where the project analysis was carried out in accordance with a European Council Directive for assessing risks and environmental impacts. This is a process which, while being driven by national law, is also of direct concern to the companies involved.

These requirements led the project leaders to consider how the risk of some classes of accident might be better established and, in particular, what the consequences of a large LNG release might be, either in the port approach — due to grounding or collision; or alongside — due to fracture of the hard arm.

The company concluded that such a large release of LNG had never happened. Nevertheless, in some situations such an event was found to be feasible. From a marine viewpoint the scenarios which could lead to a major release were identified and recommendations were prepared to further reduce the chance of any such happening.

This paper also draws on earlier publications from SIGTTO and similar societies which are relevant to the management of port risks.

4 INTRODUCTION

At the time of site selection, the level of marine risk is determined by the position chosen for the terminal and this is especially true of terminals handling hazardous cargoes such as LNG. Once the port is in operation, the risks identified during planning should be controlled by suitable equipment and pre-arranged procedures. This should include the on-going need to keep other industry or populations remote from the plant.

As can be seen from much of its earlier work, SIGTTO urge acceptance of a wide range of equipment and procedures for the reduction of operational risk. To supplement past work, this paper recommends that for new sites the LNG terminal, and its port area, should be examined as a unique risk system. This paper focuses, therefore, on accident exposure and risk management not only during cargo operations alongside, but also during the port transits of LNG carriers.

Implicit in site selection is the recognition of risk. As described elsewhere [3], risk consists of a combination of event frequency and consequence. Thus, port designers are often faced with a number of choices when selecting a site, and these choices can arise from a variety of competing pressures. As described in risk assessment theory, operational solutions are found by acceptance, or non-acceptance, of some categories of risk. However, whatever remote frequencies may be tolerated for a smaller release, there is no acceptable frequency for a large release.

In essence, the issue being addressed is how best to minimise port risks by design factors at the start of a project. As can be seen in the paper there are three components in this equation. Initially questions on satisfactory jetty position and design are covered. Operational procedures are then addressed. Thereafter, having questioned the robustness of these procedures with respect to human elements, the consequences of collisions and groundings are studied and methods of limiting the effect of such accidents are considered. By this means, any high risk scenario is identified during design and this then requires special handling to restrict occurrence.

From a navigational standpoint and as alluded to in the above paragraph, the paper suggests that while the human controls called upon during ship manoeuvring deserve high ranking, of themselves, they can never be considered one-hundred per cent secure: this is because questions of human error can prevail. However, back-up is achieved if it is known that, in a grounding or collision, an LNG

carrier's cargo containment system is most unlikely to be breached. To achieve this end, a detailed study of each port approach is needed and, to give this subject greater clarity, examples are given at section 10.3.

To cover the main risks (as identified), the possibility of liquid spillage during cargo operations at the jetty is also discussed. Here, a three stage solution is offered. First, well deployed moorings. Second, well engineered and interlinked ESD systems. Third, the fitting of PERCs, with quick-acting valves included on either side; all controlled by an ERS system.

Having addressed all risks — big and small — alongside and in the port approach, an outcome from the risk analysis which makes an accident virtually impossible is clearly the most satisfactory. If, however, the outcome shows consequences of a serious nature then, clearly, it is necessary to draw up detailed contingency plans. But, in some circumstances, such as a large LNG release close to a populated area, it may be impossible to devise a realistic contingency plan because of the nature of the problem. Herein lies a conundrum which may only be resolved by further reducing the chance of a major release by designing-out the problem.

The precautions, as recommended by SIGTTO in this paper, do not offer a single package that reduces operational risk to some quantifiable and acceptable level; indeed it is suspected that the pattern of operational risk is too complex to be easily handled in this way. However, this cautionary note aside, the industry's objective must be to further reduce risk whenever possible.

Of course, the safety of life is vital, and so also is continuing public confidence in the trade. However, the enormous financial exposures of LNG projects also must be safeguarded. In some circumstances it is found that the protection given to save life also protects the commercial exposure. In other cases, however, personal safety can be assured while unacceptable business risks remain - so suggesting the improved standards, as recommended in this report, are necessary not only due to personnel hazards but also to protect the business risk.

Important factors such as personnel training, contingency planning or matters of a general safety nature are not covered in this paper; the aim has been to focus more on matters of equipment and issues of navigational interest. Nevertheless, these extra factors are fundamental to future safety in the LNG sector and, as a matter of course, should always be taken into account.

5 DEVELOPMENT OF LNG STANDARDS

The history of developments in the LNG industry has been marked by two separate but interwoven strands. Firstly there was a continuous effort to design systems to reduce the probability of large escapes of gas. On the other hand extra standards — often oil industry based — were re-specified in light of experience and technological improvement. Indeed, as the LNG industry moves into the 21st century it remains true that future improvements should not be altogether separated from progress in the oil world and, where possible, LNG terminalling standards should continue to grow in parallel with port operations generally.

An example of an LNG standard having developed along technological lines is that covering on-shore storage tanks. For a period, earthen embankments were used for support against the force of sudden release from the inner tank. Subsequently, through adoption of improved inner tank material, the probability of catastrophic crack propagation was much reduced. Now, earthen bunds are no longer needed. Similar changes occurred in the design of LNG carriers, where sophisticated methods for assessing crack propagation now allow the secondary barrier to be omitted in two free-standing cargo containment systems - the Moss Rosenberg spherical design and the IHI prismatic design.

To date, the greatest investment to reduce port risks is the limitation of gas escape at the ship/shore interface and on the jetty. Here the application of industry recommendations for jetty design and mooring systems [4] provides a secure base for LNG transfer. Furthermore, the references mentioned in chapter 6 direct port designers to construct jetties handling hazardous cargoes in remote areas

where other ships do not pose a (collision) risk and where any gas escape cannot affect local populations. When this advice is combined with that from SIGTTO [5] — as outlined in section 7.2.2 — risks at the jetty are vastly reduced.

It can be seen, therefore, that progress in defining LNG standards have taken a step-by-step pattern which can be summarised as follows:

- a start was made with the existing framework of standards for oil
- these were then adapted for the characteristics of LNG
- changes in shipping and terminalling standards were then addressed, and
- finally the engineering challenges for cryogenic systems were answered

Present day standards for limiting problems are thus the result of sensible evolution rather than a well-focused set of risk related measures. Indeed, experience shows that the process was, simply, one of progressive improvement, the motivation being a desire to make operations safer. However, it is at the time of site selection that the foundations of high quality risk management can be laid and where overall cost/benefit judgements are best formed and it is in these areas where this paper recommends the introduction of risk management techniques.

Although the criteria for site selection may differ between LNG terminals, the majority are common to all. Some, such as the proximity of the plant to centres of population, lie beyond the pure marine interest and outside the main scope of this paper. But others, including the harbour movements of LNG carriers, the density of marine traffic (covering the nautical risks to LNG carriers) and the terminal itself, much influence the overall risk which eventually has to be controlled and these concepts are covered in more detail in the following chapters.

6 SITE SELECTION

6.1 GENERAL

At its most elementary level, site selection for LNG loading terminals is predicated by the location of production areas and, at receiving terminals, the situation is dependant upon the location of markets. Thereafter, fine tuning within the selection process is influenced by the optimisation of infrastructure costs such as gas transmission systems, access to trunklines and other distribution networks.

Hence, site selection is driven largely by factors aimed at minimising transportation and storage costs. With this in mind, it can be appreciated that marine criteria are only a part of the overall process. Therefore, at the stage of site selection, input from marine experts consists mainly in optimising fleet capacity (numbers and sizes of ships) and checking civil engineering matters at the ship/shore interface, at the terminal and in the terminal/port approach. This latter aspect is achieved by obtaining the required depth of sheltered water, providing good access to the sea and achieving immediate adjacency to the LNG terminal.

From a marine viewpoint there is little prospect to escape from these basic factors. Prices and hence, to a large extent demand, remain linked to the costs of alternative energies and, LNG's unique environmental benefits notwithstanding, the product must retain market competitiveness. Thus, as the future unfolds, continuing efforts to economise on handling costs and freight rates are likely.

In the site selection process the challenge, therefore, is to limit marine risks while positioning the jetty within realistic limits. Already there are generally accepted criteria and regulatory requirements to guide port designers in achieving this synthesis and most are covered in this paper.

6.2 JETTY LOCATION

The recommended site selection process removes as many risks as possible by placing LNG terminals in sheltered locations remote from other port users. References [6], [7] and [8] all direct port designers to construct jetties handling hazardous cargoes in remote areas where other ships do not pose a (collision) risk and where any gas escape cannot affect local populations.

Furthermore, choosing a jetty position within a sheltered location limits the dynamic forces acting on a ship from sea-waves which, in turn, could break a ship's mooring lines. Considering the standard LNG carrier of about 135,000 m³ capacity, the waves likely to have such effects are those approaching from directly ahead or astern, having *significant heights* exceeding 1.5 metres and *periods* greater than 9 seconds. Seas approaching the berthed ship from an incidence angle of 90° (to the bow) have much lower cut-off points. It is, therefore, recommended that harbour protection be provided against low frequency waves, either by choice of location or by construction of an effective breakwater. Alternatively, an enhanced mooring system may be designed, suited to dynamic effects (but also taking into account the suitability of gangway access for the moving ship). Without such assurance the mooring system, which is the only defence against ship break-out, could be put at risk.

Jetty location should also be chosen to reduce the risk of passing ships striking a berthed LNG carrier but subjective judgement comes into assessing safety from this standpoint. The acceptability of such positions should be determined only after detailed consideration of local circumstances. However, as far as port design is concerned, some features are clear cut. For example, positioning an LNG terminal on the outside of a river bend raises the risk that a passing ship may strike the berthed carrier if the manoeuvre is not properly executed. This is possible because, at some point on the bend, the manoeuvring ship must head directly at the berthed LNG carrier. In this respect, and following the reasoning in reference [3], ships of over 10,000 tonnes displacement operating at normal harbour speeds — say 10 knots — when striking at 90°, present a hazard to a berthed LNG carrier's containment system. It follows, therefore, that building a jetty in such locations is normally considered unsuitable.

Furthermore, large ships passing near to a berthed LNG carrier can cause surging or ranging along the jetty, with consequential risks to the moorings and this phenomenon should be guarded against. This can occur at jetties located in channels used by large ships and, because of this, these positions are not recommended.

The added risks from increased traffic encounters, and extended shallow-water navigation, when positioning an LNG jetty farther inside a port, must also be considered — but these risks are covered more fully in chapters 9 and 10.

As can be seen, choosing the site for an LNG jetty comprises a mixture of checks, some derived from quantitative analyses, others owing more to subjective judgement. However, when considering an LNG carrier alongside, site selection is directed mainly at minimising the risks of ship strikings, limiting interactive effects from passing ships and reducing the risks of dynamic wave forces within mooring lines.

7 DESIGN CRITERIA FOR JETTIES

When the site selection process finally establishes the best position for an LNG terminal, its design is set within two sets of criteria — root criteria and specific criteria. These are categorised as shown below.

7.1 ROOT CRITERIA FOR HAZARDOUS LIQUID CARGOES

Basic safety for gas, chemical or oil tankers and their respective terminals is governed by ISGOTT [9]. This book contains an essential list of design and operational practices and is amended from time to time in accordance with new experience. In addition to ISGOTT, in establishing safe designs, the use of other guidelines published by SIGTTO, OCIMF, IAPH, PIANC, IALA, and BSI is encouraged. Some of these documents are referred to in chapter 11 — see references [10], [11] and [12]. However, most of these industry documents are general in nature and seldom discuss event frequency nor, for that matter, specific ship-types. In order to cover the hazards more effectively, reference [13] is of help in the gas trades — although written more from the viewpoint of existing plant.

Until the publication of this paper, within the standard suite of industry publications, the possible consequences of an accident are also left largely unaddressed. Previously, it was only reference [14] which gave some guidance on this subject. However, taken together, these older sources provide a robust framework of root criteria around which jetty designs are established and other standards (specific criteria — see below) are then specially tailored to the needs of LNG.

Thus, existing recommendations provide the root criteria for jetty design, in terms of:

- strength of mooring systems
- positioning breasting dolphins
- position, size, and spacing, of hard arms
- depth, width, and alignment, of harbour channels

Such recommendations provide terminals with a good set of design standards. They are not, however, exhaustive nor can they be applied without knowledge of local conditions, so they can rarely be used to prepare a complete checklist for LNG — other measures must be adopted (see section 7.2).

It can be seen, therefore, that within the root criteria, a system is established for securing a safe berth; but this is one within which there may remain a significant, albeit remote, probability for an accident to happen. In developing criteria suited to LNG the separation of each risk into its frequency and consequence is crucial. Thus, when considering even the remote possibility of major accidents, the application of existing standards, though relevant, is insufficient to obtain suitable assurance. Accordingly, at LNG jetties, risk related methods should be adopted which address event probabilities, and seek, as far as possible, to quantify the frequency of occurrence.

7.2 SPECIFIC CRITERIA FOR LNG

7.2.1 General

Although the root criteria, as discussed above, are included in LNG terminal design, risk considerations usually identify the need for yet other equipment or procedures — the site specific criteria. These methods can be more demanding than the root criteria and are often applicable to operational practices and geographical areas for which industry guidance is not yet fully established. However, a new series of standards from CEN, entitled Installations and Equipment for Liquefied Natural Gas, will be appropriate to European usage — perhaps even further afield.

Additional specific criteria are also found from risk factors lying beyond normal operations at the ship/shore interface. These conditions can include hazards from outside influences such as other marine traffic and nearby ignition sources. As an example, some LNG terminals patrol the perimeter of the offshore safety zones with guard boats — see section 7.2.4. A further example is to declare the air-space over an LNG terminal as being a restricted zone where no aircraft is allowed to fly without written permission.

The specific criteria have thus grown through experience in analysing and managing terminals. They have wide application in the reduction of risks at LNG terminals and are therefore included among the recommendations to be applied during terminal design. In the following sections some specific criteria are discussed in greater detail.

7.2.2 Mooring

For the LNG trades, site selection includes extensive collection of environmental data, including wave spectra. From this, the oscillations of berthed ships are estimated and the individual loads in each mooring line are pre-calculated for critical conditions. Within the trade, this means that not only mooring standards [4] should apply but also the additional force of dynamic wave action should be taken into account. So, while the root criteria for mooring systems act as the design basis, the behaviour of mooring and cargo handling equipment is made site specific for the prevailing conditions. These analyses establish jetty specifications for:

- mooring bollard strength and position
- mooring load-monitoring equipment, and
- hard arm envelopes and cut-off points for automatic operation of the ERS system

7.2.3 Cargo Transfer Operations

All LNG companies ensure that gas carriers can lie safely alongside while transferring cargo. Here, references [14] and [15] are of great value in achieving this aim. By adding the standards for ship's cargo manifolds and detail on surge pressure control [16], which are among the many valuable contributions made

in recent years, even greater assurance is provided. Yet experience shows that specific criteria should be adopted to adequately control risks over the whole spectrum of port and terminalling operations and these should find a place in the design. In this respect, to guard against the consequences of hard arm failure, specific criteria should limit the possibility of significant LNG spills. This question is addressed in reference [15] where the following equipment is recommended to be fitted at hard arms:

- interlinking of ship and shore ESD systems
- establishing a common standard of linkage for ship/shore ESD control
- fitting PERCs and their quick-acting valves
- linking ESD systems and PERCs into a unified control system called ERS

In addition to other matters, reference [5] takes a fresh look at the operation of Emergency Release Systems (ERSs) where it will be found that many events can cause triggering of the system. For the purposes of this paper it should be noted, however, that the ERS is expected to function in two distinct steps. The first step is cargo pump stoppage and closure of the ESD valves in pipelines, both on-board ship and on shore. The second step is closure of the quick acting valves (at the PERC) and the release of the PERC by automatic means. More detail may help to explain this two-stage operation. Here, it should be appreciated that within the ERS's electronic logic for the hard arm, sensors are installed to detect ship movement. Some movements are within the proscribed limits; others are of significance; and yet others are dangerous. Ship movements to the outer edge of the safe area may trigger an alarm. However, movements into the first ERS area activate valve closure and pump stoppage (ESD) — this is still an intermediate area but one in which automatically initiated controls are considered necessary. Finally, if the ship moves beyond this intermediate zone — into the danger area — automatic release of the PERC is actuated quite independently from human intervention.

To illustrate this concept a diagram is provided below.

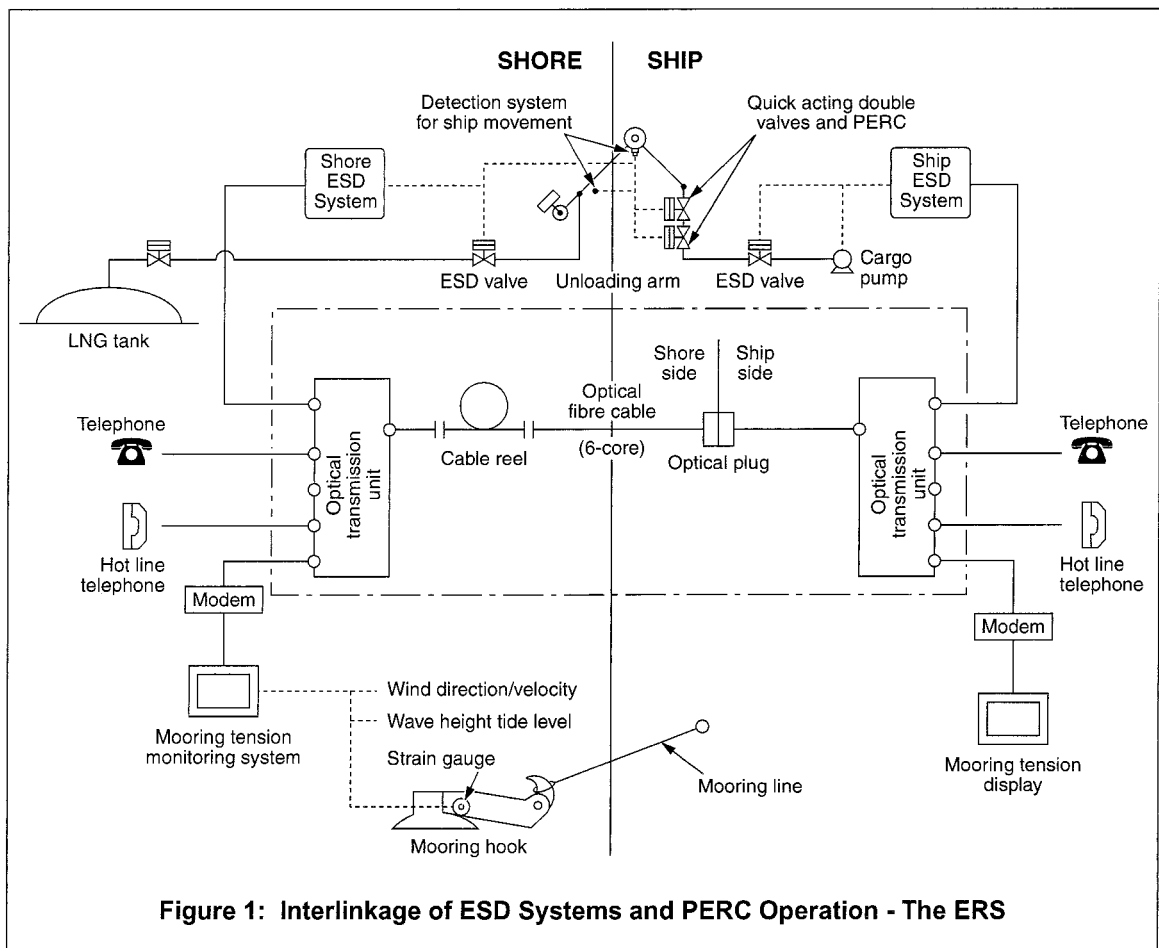

In developing these criteria, the underlying rationale is that the mooring lines must provide secure attachment between ship and shore allowing very little relative movement. This means the hard arms also remain secure and the risk of arm rupture, caused by ship break-out, should not occur. However, although this basic framework underpins safety at the ship/shore interface, it provides only a single defence against risk of spillage and the generation of dangerous gas clouds.

Therefore, a second defence comprising an interlinked ESD system is used, this being manually activated by the jetty operator or automatically by ship movement beyond the limits of a predetermined envelope. Automatic activation is triggered (amongst other alarms — see reference [5]) when sensors in the ERS system detect unacceptable ship movement so allowing the ESD controls to stop cargo flow and close pipeline valves — usually within 30 seconds. The progress of activation must be first to stop the pump and then to close the valve nearest to the pump — this restricts the magnitude of surge pressures so limiting any risk of hard arm damage because of high transient over-pressures.

However, and as mentioned above, it is recommended that a third defence be provided to ensure protection for the hard arms against damage from ship break-out and further reduce the maximum quantity of LNG spilled. This is the inclusion of PERCs (fitted within the arms) which allow hard arms to be safely, quickly (about 5 seconds), and automatically disconnected if an LNG carrier should break-out from its jetty. Hence, if all else fails and an LNG carrier breaks away from a jetty the maximum spill is no more than about 15 litres of liquid for the standard 16 inch diameter arm.

Safety issues apart, the PERC (and its accompanying ERS system) is a highly desirable protection of business interests. Often the jetties at LNG installations are but single entities, and if put out of action, total supply can be severely jeopardised. It will be seen, therefore, that in LNG projects, where massive investments are involved and the income of many parties depend on uninterrupted cargo deliveries, any risk of damage to jetties must be eliminated as far as possible. For these reasons, SIGTTO believe that such equipment is an essential risk reduction technique.

Further measures to prevent gas release include surge pressure control systems. Because surge pressures can cause hard arm and pipeline damage, the cargo handling system must be designed by keeping the possibility of surge in mind. This may lead to increased scantlings for pipelines, the fitting of bursting discs with surge pressure drums, or quick-acting relief lines returning surge pressures to the cargo tank.

7.2.4 Ignition Risk

In the event of an LNG spill the possible extent of a gas cloud must be considered. Here it should be appreciated that the risk of ignition from spilled LNG can extend for some considerable distance and, therefore, ignition controls must extend beyond the immediate area and this may be both inside and outside the terminal boundary.

Clearly, it is important to remove all risks of ignition as far as it is practicable to do so. Procedures taken to limit the risk of spills, and minimise their scale, reduce the probability of gas cloud ignition. But even the marginal risks remaining can be unacceptable in a business where a first rate safety record is vital to sustain confidence. Further precautions are therefore adopted to limit ignition sources on the jetty and in its environs.

As mentioned in section 7.2.1, in some ports guard boats are used to patrol the offshore safety zones with a view to excluding other traffic. Often these craft are also fitted out for other emergency purposes and feature in contingency plans. Figure 2 below shows the general arrangement for one such craft.

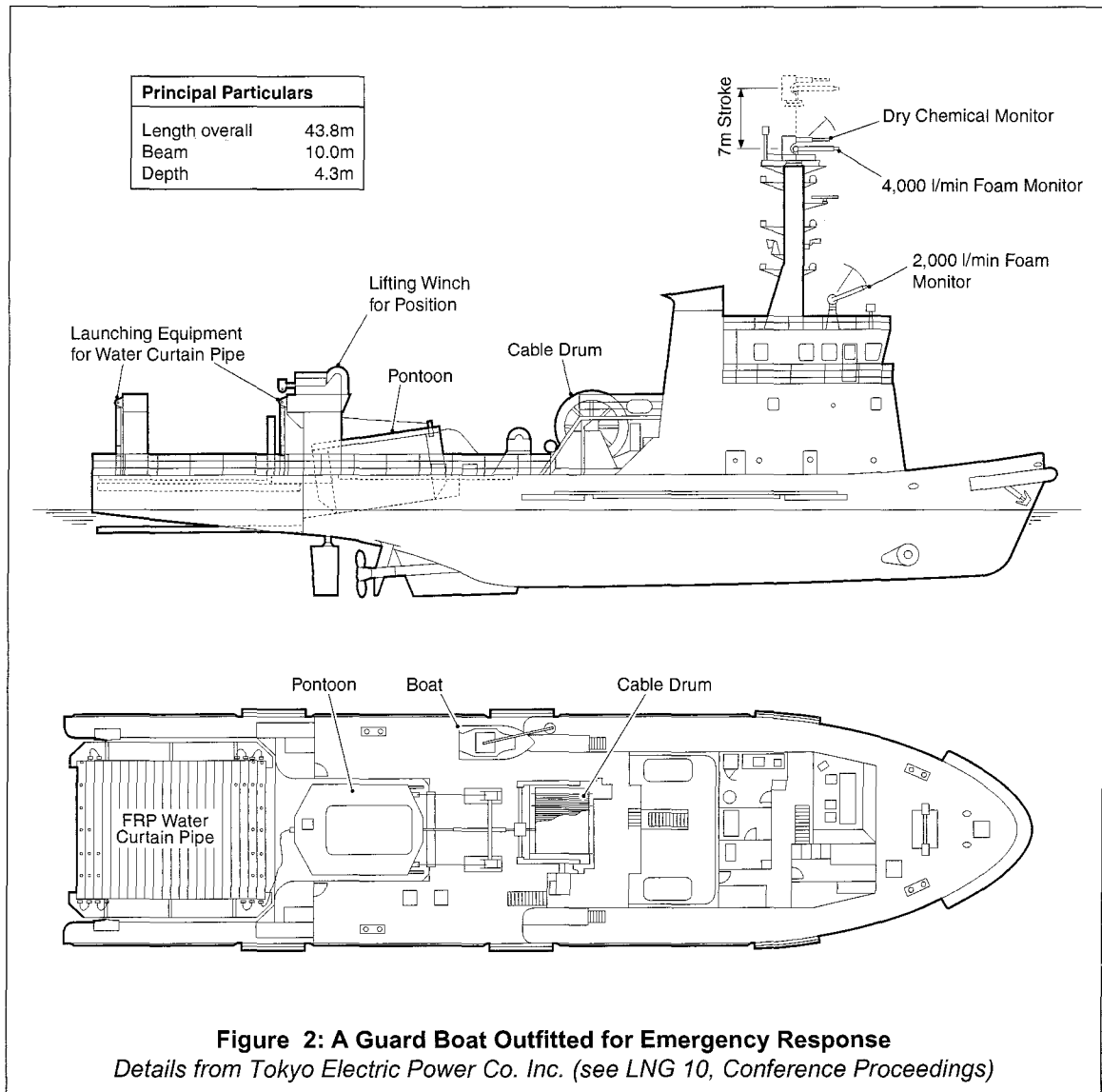

The area over which ignition-free zones should extend is determined by an analysis of the formation and dispersion characteristics of gas clouds resulting from a range of spill scenarios under a variety of weather conditions. The result provides the likelihood and possible extent of gas clouds in the vicinity of the jetty.

The range of a flammable gas cloud generated by a spill is principally dependant on spill rate and duration but inevitably some subjectivity must accompany the assessment of each spill scenario. Other factors such as climatic conditions, wind direction and speed are also of importance. In addition local topography such as harbour structures and the presence of the LNG carrier itself can have an effect.

Thus, determination of the minimum area from which all ignition sources must be excluded will vary from terminal to terminal and such determination should form part of the design considerations. Sometimes quite large zones, free from ignition sources, are considered desirable especially when terminal safety systems such as fire pumps could be engulfed within the gas cloud.

7.2.5 Specific Criteria - a Summary

In summary the essentials for a safe LNG berth are as follows:

Essential design for a safe LNG jetty

- find a location suitably distant from centres of population
- provide a safe position, removed from other traffic and wave action
- construct mooring points in a satisfactory array and of suitable strength
- use hard arms for cargo transfer
- interlink ship and shore ESD systems
- provide a two stage ERS system, linking ESD protocols with PERC operation
- fit hard arms with PERCs, together with quick acting valves
- fit wind speed and direction monitoring equipment
- install load monitoring equipment on mooring line quick release hooks
- determine maximum credible spill, gas cloud range, and ignition-free safety zones

Apart from the essential design factors listed above, the following terminal procedures should be in place.

Terminal procedures for the LNG carrier alongside

- set limits on the mooring system for wind speed, wave height, and current
- set wind limits for cargo stoppage, hard arm disconnection, and unberthing
- restrict the speed of large ships passing close to berthed LNG carriers
- control visitors and vehicles coming into jetty safety zones
- establish ignition-free offshore zones to stop entry by small craft
- disallow simultaneous LNG operations and ship movements at adjacent jetties
- have available local weather forecasts with suitable warning systems
- have pilots and tugs ready at short notice for emergency departure

Port planning should also ensure that advance procedures are available to control a ship's port entry. In this regard it is most important that each arrival is carefully agreed between the ship and terminal. In particular this should include up-to-the-minute information on berth availability, especially in times of bad-weather forecasts, when last minute changes in berth availability can be anticipated. To safeguard ships in transit from any last-minute change in status on berth availability a contingency plan should be available to include detail on suitable anchorages, lay-by areas or turning circles where the ship can wait or turn round to proceed back to the port entrance.

As a port moves into the operational phase critical revision of existing port procedures is recommended on a frequent basis. By this means, ship operators and terminal managers can be continually assured that cargo planning procedures remain valid, tugs numbers (and power) remain suitable and that matters of contingency planning remain up to date.

8 RISK MANAGEMENT IN THE PORT APPROACH

National authorities and LNG companies devote considerable resources to reduce any risk that an LNG terminal may present to the port environs. This is most apparent during design when special emphasis on the security of nearby population centres is obtained by applying Environmental Impact Assessments and application of references [6] and [8]. At this stage, the risks associated with an LNG carrier as it navigates through the port approach are also addressed and, to illustrate these matters, typical safety routines for the offshore areas are listed in the following paragraphs. Reference may also be made to publications from IAPH, PIANC, BSI and IALA on this subject and some of these standards are given in chapter 11.

8.1 PORT CONTROLS

Taken globally, the frequency of nautical accidents, such as strikings, collisions and groundings, to any class of ship are greater in port approaches and during berthing when compared to frequency rates at sea. For the whole class of gas carriers (LNG and LPG) such accidents account for over half the total reported and, when time factors are taken into account, this confirms that the opening statement also holds true in the gas trade. However, from historical records, it is good to report that serious incidents of this type are extremely rare for LNG carriers; indeed, only one such incident (a grounding) is known to have occurred at a receiving port, none at a loading port and none at all anywhere in the world since 1980.

This successful management of LNG ports can be explained only by the controls unique to the LNG business which have a significant risk reduction effect. At present these distinguishing features consist of:

- effective VTS (traffic management) and the use of escort craft
- adequate tug power to control LNG carriers, even in dead-ship conditions
- strict operating conditions
- regular ships in each trade, and
- high quality seagoing personnel

Some of these points are further explained below:

8.1.1 Vessel Traffic Systems (VTS)

Establishing safe conditions for the port transit of LNG carriers is always a matter of importance. This is usually a direct responsibility of the port authority. However, operational risk management on a day by day basis is a task shared between port authority, terminal owner and ship operator. In most cases there is agreement over the procedures required to assure low risk levels but, as a minimum, a good VTS system, as specified by the International Maritime Organization (Resolution A.578-14) for marine traffic management is recommended to prevent close encounters between LNG carriers and other ships.

Subordinate specifications concerning traffic management, such as the safe distances for other ships to pass LNG carriers, depend on the risks identified in particular situations. For example, in areas of high traffic density, the shore-based VTS may be supplemented by an escort craft (or guard boat) to attend the LNG carrier; in other situations, the VTS may suspend other traffic movements in the channel during the LNG carrier's approach. Whatever specific arrangements are made, they should aim to much limit collision risks caused by close encounters with other ships.

Other conditions for establishing safe operations in port are similar to those required for the harbour movements of any large ship, such as, adequate navigation marks and lights, limiting ship movements in poor visibility, and a high standard of pilotage service all of which contribute to minimising the risk of grounding.

The quality of pilotage service is particularly important. As part of terminal planning it is vital to secure not only consistent high quality in harbour pilotage operations but also to fix pilot boarding areas at

a suitable distance offshore, beyond which the LNG carrier is not allowed to continue inwards without the pilot being on board. Many port authorities use navigational simulators for training their harbour pilots and, when used wisely, simulator courses can yield valuable results. Not least among the advantages of simulator training are the benefits which can be gained by learning how to build good bridge teamwork and an appreciation of Passage and Voyage Planning routines.

In another context, (see section 6.2) marine traffic management can also be important when the position of the jetty is taken into account. If large ships are allowed to pass close by, interactive effects can cause mooring line failure on the LNG carrier. Although such locations are not recommended, depending on the site chosen for the terminal, it may be necessary to limit the speed of passing ships and this may be achieved by VTS controls.

8.1.2 Tugs

Following the same weather which determines port design parameters, the operating limits for LNG carriers should also be specified in terms of wind speed and current drift. These parameters are then used to calculate the maximum wind forces acting on the largest LNG carrier using the port, and thence the number and power of the tugs needed for berthing manoeuvres is specified. There must always be sufficient tug assistance to control LNG carriers in the maximum permitted operating conditions and this should be specified assuming the ship's engines are not available. This method gives different results from one terminal to another. Accordingly, minimum tug power is not an absolute value. Nevertheless, it has been found that for LNG carriers of 135,000 m³ capacity, acceptable standards are usually in the range of three or four tugs having a combined bollard pull between 120 to 140 tonnes. These tugs should be able to exert approximately half of this total power at each end of the ship. Given that four tugs are provided, in terms of tug propulsion, this suggests that each tug should have engines capable of a minimum of 3,000 horsepower, although this is dependant on propeller configuration.

8.1.3 Operating Conditions

When port design is being considered the aim should be to limit navigational risks involving LNG carriers within the port area. The extent of the system developed depends on factors such as:

- number and type of ships and other craft using the port
- port accident records
- navigational distances and difficulty through the port and jetty approach
- the maximum draft of the ships
- the nature of the sea-bed (rock, sand or mud)
- tidal conditions (tidal ranges and tidal currents)
- weather conditions (wind, waves, sea-ice and visibility)
- proximity of the terminal to populated areas and industrial sites

After studying such factors, port designers and port authorities can introduce LNG-related provisions appropriate to the local port. The operational procedures and equipments which follow from these considerations, and already adopted in many LNG ports, are summarised below.

8.1.4 Summary of LNG Port Procedures

Port procedural limits for weather

- establish weather limits for port closure
- draw up procedures to give advance weather warnings to ships
- restrict port manoeuvring of LNG carriers in strong winds
- restrict port manoeuvring of LNG carriers in reduced visibility
- establish safe anchorages at the port entrance and within the harbour

Port controls for approach channels

- provide suitable short range navigational aids for approach channels
- provide escape routes in cases where a ship is unable to berth
- establish port suitability for day and night transits
- set safe manoeuvring limits for, visibility, wind, current, and wave height
- relate channel widths to the beam of the largest ship
- relate turning circle diameters to the length of the largest ship
- set speed limits for channels to limit heavy groundings or penetrating collisions

Port controls for tugs and escort craft

- set safe weather limits for berthing
- provide tugs farther to seaward; beyond the normal 'assistance' area
- provide escort craft suited to the circumstances
- establish tug power as being sufficient to overcome maximum set wind conditions
- have pilots and tugs available at short notice for emergency departures

Procedures and systems regarding traffic control

- establish a VTS control to coordinate the movement of all craft within the port
- limit other traffic movements in the port while LNG carriers are in transit
- set a moving safety zone in approach channels ahead and astern of LNG carriers
- adopt Traffic Separation Schemes (TSS) in appropriate approach channels

In addition to these points other operational factors should be addressed. These can include instructing ships to carry appropriate charts and nautical publications and to implement Voyage Planning routines. Port authorities should also ensure that harbour pilots use the practice of Voyage Planning. However, being more in the realms of ship operation, these issues fall beyond the scope of this paper.

Study of the foregoing lists shows that only rarely are the criteria absolute, or conditions unchanging. Obviously water depth is critical, as are severe weather conditions, but in many other cases either the procedures, or the conditions they are set to control, have flexible application. Indeed, it is suggested in reference [14] that the principal value of listing the criteria is to identify the hazards with a view to setting operational procedures to control them. Similar reasoning is evident in reference [1], and its check list of risk reduction options is used as a basis for the Appendix to this paper. Hence, within many existing navigational controls, it is usual, as a consequence of human factors, for a low level of residual risk to remain. Under present industry guidelines, this is true even after the optimisation process for site selection is complete. Thus, in some existing ports this risk remains to be controlled on a day by day basis.

Of course, for new terminals, present day standards involving Environmental Impact Assessments, and similar procedures, should be even more effective in securing a low risk operation. However, within these systems, expert marine advice is necessary to ensure that, when a large gas release is considered, limited only by human elements, the consequences are controlled by other methods such as those discussed in chapters 9 and 10.

9 THE HUMAN ELEMENT

Accident reports show that effective risk management, whether in port or at sea, is often frustrated by an inability to completely obviate human error or uncharacteristic human behaviour. Indeed, the large majority of shipping casualties continue to occur as a result of the human element. But the relationship between operator error and risk assessment remains obscure; this is because human responses are difficult to predict and the process of human reaction is not fully understood.

For these reasons, risk management systems usually take the possibility of human error into account, attempting to control it by other means. Such methods can include alarms, ESD systems, engineered

fail-to-safe equipment, equipment redundancy (back-up), and procedures. As appropriate, these devices include multiple cross-checking features. The positive contribution of all these measures to risk reduction is clear. However, casualty data shows (see sections 8.1 and 10.1), that even for LNG carriers, current techniques involving human controls are less than one-hundred per cent effective. Thus, when limiting the chance of a significant accident — to match a very low risk exposure — the range of industry standards covered in chapter 8 are found to be less than foolproof.

This paper suggests, therefore, that it is necessary in the port approach, to adopt a method of risk management which, as far as possible, discounts the contribution of human judgement. In particular, this chapter not only addresses the need to consider accidents where human judgement has proved helpful in limiting the consequences but also to consider the increased risk in some areas when human controls have failed — perhaps thus endangering the ship's cargo tank containment system.

Drawing on the discussion in chapter 10, the ship's speed which may damage the cargo containment system can be estimated. By this means, for parts of the port approach, speed controls can be established to limit the consequences of collisions, strikings and groundings. In the case of a ship grounding it is possible to assess whether the potential damage might cause cargo containment system rupture. This can be done by:

- reference to the quality of the sea-bed
- assessing the possible courses of the grounding ship
- estimating the ship's speed at the time, and
- applying the criteria given in references [17] and [18]

A similar list of criteria can be developed for collisions but the first item, as listed above, would be omitted and another added; viz, the angle of strike. In addition, references [19] to [26] should be studied.

This paper suggests, therefore, that each port should be investigated for the presence of the dangers which could cause critical impacts during the harbour transit of an LNG carrier and recommends that port designers, when assessing individual hazards, take the possibility of human error into account. This should be done to ensure a satisfactory safety margin is provided — that is, in the event of accident, an assurance ruling out cargo containment system rupture. It can be seen therefore that, when using this method, the following listing of existing safeguards are assumed to fail:

- operational procedures
- back up system warnings, and
- human controls

Evidently (see chapter 10) such high risk events are extremely rare in LNG shipping. Nevertheless, only after the above investigation has been completed can appropriate assurance be secured which protects a ship's cargo containment system against rupture. Because of the unquantifiable nature of the human element, this paper suggests that only by removal of all possibilities for containment system penetration can the correct level of port security be obtained.

10 GROUNDING AND COLLISION RISK

With respect to ship navigation, any hazard which may result in a large release of LNG can be identified by assessment of the energy necessary to penetrate the ship's inner and outer hulls. The double-hull arrangement provides LNG carriers' containment systems with protection to all but high impact. This means that, as part of port design there is every prospect for preventing a large gas release without introducing unrealistic port restrictions. However, and following from chapter 9, it should be seen that an important element to avoid, where possible, is any procedure over-dependant on human controls.

In this chapter, therefore, consideration is given to LNG carrier groundings and collisions with a view (through ship operation and port design) to reduce the risk of major gas releases. Clearly, once a terminal is in operation, knowledge that such accidents are virtually impossible, provides valuable input for future operations.

10.1 HULL DAMAGE - A HISTORICAL REVIEW

Analysis of SIGTTO and other casualty records give a reliable picture of the accident profile of the LNG shipping industry in the period between 1982 and 1996. However, because some categories of minor incident were considered unreportable, it is probable that the data is incomplete. Nevertheless, it is virtually certain that the data includes every incident, such as grounding and collision, having potential for damaging a ship's cargo containment system.

The data-base shows that the cargo handling and port-related accidents recorded in this period, and with the ships fully operational, numbered only ten. Of these:

- one occurred whilst manoeuvring in a port (propeller struck channel buoy)
- five involved ships breaking out from the jetty with the hard arms connected
- three involved mechanical failure, and
- one records a fire on the engine room switchboard

In none of these cases was the LNG carrier's cargo containment system put at risk.

For the period between 1962 and 1982 the data is less comprehensive, but still it is extremely unlikely that any significant incident, threatening an LNG carrier's cargo containment system, would have gone unreported. In this period there are only six accidents which might be categorised as posing a hazard to the ship's cargo containment system. Within this time frame there are five reported collisions and five reported groundings. One of the collisions involved an LNG carrier being struck whilst berthed, the others were outside port and none resulted in serious damage to the cargo containment system. Of the groundings only two (one in port and the other at sea) involved serious structural damage to the ship's bottom and in neither case was the cargo tank containment system penetrated.

The two serious grounding incidents demonstrate the capacity of LNG carriers to sustain bottom damage without experiencing rupture of the containment system.

Records show that there are no comparable data that would similarly demonstrate the resistance of an LNG carrier's side structures to collisions. Nevertheless, there are tools available for predicting such resistance, giving results which, when used with care, are able to establish the minimum energy required to put a cargo containment system at risk — see section 10.2.2.

So, although it has never happened over some three decades of LNG carriage, an important risk to be considered in port analysis is the possible release of cargo during groundings or collisions. Though open to interpretation, good estimates are available for the energy required to penetrate an LNG carrier's double hull so putting the ship's internal cargo tank containment system at risk. It is therefore possible to identify accident scenarios with potential for such damage and plan to remove them from port areas. Accordingly, when designing a port, the aim should be to limit the probability of high energy impacts on LNG carriers, such that damage to a ship's hull is minimised.

10.2 RISK OF STRUCTURAL DAMAGE TO LNG CARRIERS

10.2.1 General

The structure of LNG carriers, incorporating double bottom tanks and double sides, gives high resistance to the impact of grounding and collision. This is supported over many years of research (see references [17] to [26]), some of which is described in the following sections.

10.2.2 Collision Damage

One method [19], in which collision energy is assumed to be absorbed by the structures of both ships was, for many years, the accepted way for assessing collision resistance. Predictions using this method relied upon empirical resistance factors, mostly derived using data from actual impacts. More recent methods (see chapter 11), which include a better understanding of failure and collapse mechanisms, have led to more accurate predictions and these methods seem to be especially effective for low energy collisions; although the method first mentioned still gives acceptable results in high energy situations.

The results of such analyses are dependant on the impact angle (of the striking ship), the bow shape of the striking ship and the structure of the struck ship. Therefore conservative interpretations must be placed on such analyses, particularly if the results are intended to support the conclusions of a wider risk assessment.

Significant studies on the question of collision damage are included in the references. Based upon published methods, the following table lists examples of the resistance of a stationary 135,000 m³ LNG carrier, expressed against the critical impact speed required to hole the outer hull but not to rupture the cargo tank containment system.

Hull Resistance for a 135,000 m ³ LNG Carrier	
Displacement of Colliding Ship (tonnes)	Critical Impact Speed (knots)
93,000	3.2
61,000	4.2
20,000	7.3

For the reasons indicated above, the results shown in the table are considered to be realistic and provide conservative estimates — so allowing a satisfactory margin for error.

10.2.3 Grounding Damage

Typical publications covering grounding damage are listed in the references — in some cases a reference may dwell on oil tanker topics, however, with respect to the double bottom depths, as present day oil tanker design is similar to that in LNG carriers, the references remain helpful. Indeed the references suggest that the similar structure in LNG carriers gives the same level of protection from low energy grounding and similar assurance in a significant proportion of high energy incidents.

Accurate prediction of damage in grounding incidents is difficult. But, given a smooth sea-bed of sand or mud, impact energy is usually spread over a large area of the ship's bottom and, with this cushioning effect, upward penetration is minimised. Rock bottoms cause more jagged penetrations with the impact being absorbed over a much smaller area.

10.2.4 Hazardous Penetration

As can be seen from the foregoing overview, analytical tools are available which can, with reasonable accuracy, predict damage to ship's hulls in collision and grounding situations. This means it is possible to set criteria for accident severity (in terms of ship's speed) below which rupture of the cargo containment system is virtually impossible.

It therefore becomes feasible to consider ways to analyse port approach channels so that any risk of cargo containment rupture can be removed and the remote possibility of an uncontrolled release of LNG reduced to non-credible proportions.

Hence, by removing individual risks in each port such as:

- rock outcrops or reefs
- underwater obstructions, and
- close encounters with other ships

from the main shipping channels and their immediate environs, port risks can be reduced to a level where a large release of LNG becomes too remote to imagine.

10.3 EXAMPLES

In this section practical application of the recommendations given in sections 10.1 and 10.2 is illustrated by simplified examples for a hypothetical port. The port in question is shown in Figure 3.

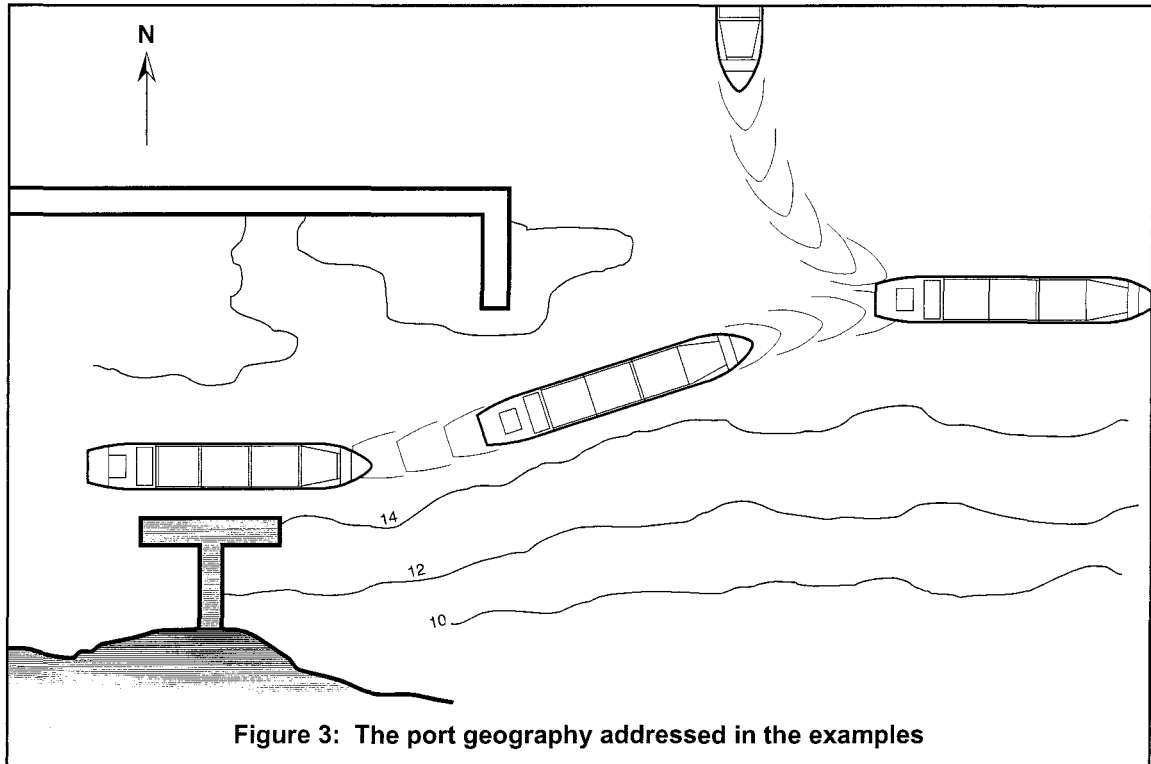

Figure 3: The port geography addressed in the examples

10.3.1 Striking a Fixed Structure - Example 1

Harbour entry is carried out in accordance with the manoeuvre illustrated in Figure 3. This involves moving stern-first through the port entrance under the control of tugs.

The following conditions are assumed to apply:

- Tug numbers, tug power, and operating conditions are specified for the port such that the LNG carrier is fully controlled by tugs alone, even in case of ship engine failure.
- Penetration of the ship's outer hull, through striking the corner of the harbour wall, is calculated to require a side-on speed of 5 knots. Furthermore, the calculations show that this damage will not extend to the cargo tank containment system. (For this scenario, the worst case condition occurs with impact on the ship's parallel body and with the transverse velocity at 90° to the point of impact).
- Misjudgment by those controlling the manoeuvre is assumed.
- At a point on the ship's track (from which impact on the corner of the harbour wall is possible) simultaneous failure of the ship's engines, and sufficient of the tugs for loss of control, is assumed. This is assessed as being possible once in 5 million operations.
- The most likely part of the ship to strike the wall is the ship's stern structure. Collision damage in this area cannot put the cargo containment system immediately at risk.

- The critical speed of 5 knots for a side-on striking cannot be achieved from any point in the manoeuvre since the ship's maximum drift speed in open sea conditions, in wind speeds of 30 knots, is calculated as just 4 knots. This wind produces conditions in which tugs cannot operate; and therefore, under such conditions, the port would be closed. In any case the wind does not contribute sufficient extra speed, to that already given by the tugs, for a 5 knot side-on speed to be achieved from the stern-first manoeuvre.

Solution

With the effects of harbour wall fendering discounted and the resistance of the cargo tank containment system ignored, the probabilities of sustaining cargo tank containment system penetration through striking the harbour wall are assessed as non-credible.

10.3.2 Grounding - Example 2

Assuming human error has occurred, the arriving LNG carrier overshoots the initial port-hand turn of the entry manoeuvre with excessive speed and, through technical failure or misjudgment, the tugs fail to stop the ship. As a result the carrier enters shallow water to the east of the jetty and grounds.

- It is assumed that the ship's last course before grounding can result in angles of impact from head-on (bow-on) to beam-on (side-on).
- Head-on grounding is assumed to have a higher speed than from other directions since any other angle of impact implies a change of course — hence speed loss.
- The sea-bed is free of obstructions and smooth, hence point penetrations are not possible. The slope of the sea-bed is two metres in every 100 metres over the ground.
- The maximum possible head-on grounding speed is assessed at 12 knots. Higher speeds are considered impossible because of shallow water effects, which slow the ship, and because the ship should have put its engines into manoeuvring mode (slower than full sea speed) well in advance. For this reason, grounding speeds for all other angles of impact must be less than 12 knots.
- Impact energy for a head-on grounding is mostly absorbed by structural damage forward of the cargo containment area, and the ship's forward speed is reduced to less than 6 knots (half the initial speed) before the ship's bottom under the cargo tanks takes the ground. The residual impact energy is then spread broadly through the bottom structure as the ship runs over a 2:100 gradient and this is calculated to be insufficient (with a smooth sea-bed) to achieve penetration of the cargo containment system.
- Groundings with the LNG carrier at any other angle to the shore, other than head-on, involve progressive combinations of speed reduction and structural deformation of the ship's bottom forward of the cargo tanks - until, with the beam-on grounding, the impact is taken wholly on the ship's side, but with a speed less than 6 knots.

Solution

Actual grounding incidents and theoretical calculations together suggest that rupture of the cargo containment system is non-credible in any of the cases.

11 REFERENCES

- [1] *Safety Requirements at LNG Terminals* - 1992, Gyles J.L., Shell International Marine Ltd, LNG 10 Conference Proceedings
- [2] *Criteria for Selection of Sites for LNG Terminals* - 1992, Gyles J.L., Shell International Marine Ltd, SIGTTO Panel Paper
- [3] *Safety Aspects of Liquefied Natural Gas in the Marine Environment* - 1980, The National Research Council (Report NMAB 354); sponsored by the United States Coast Guard.
- [4] *Mooring Equipment Guidelines* - 1996, OCIMF - ISBN 1 85609 088 4
- [5] *Accident Prevention - the Use of Hoses and Hard-Arms at Marine Terminals Handling Liquefied Gas* - 1996, (SIGTTO Information Paper No 4), ISBN 1 85609 114 7
- [6] *Recommendations on the Safe Transport of Dangerous Cargoes and Related Activities in Port Areas* - 1995, (IMO Ref 290 E) International Maritime Organization, ISBN 92-801-1329-1
- [7] *Dangerous Goods in Ports: Recommendations for Port Designers and Port Operators* - 1985, PIANC
- [8] *Guidelines for Environmental Planning and Management in Ports and Coastal Area Developments* - 1989, IAPH
- [9] *International Safety Guide for Oil Tankers and Terminals* - 1996, OCIMF/ICS/IAPH - ISBN 1 85609 081 7
- [10] *Big Tankers and their Reception* - 1974, PIANC
- [11] *British Standard Code of Practice for Maritime Structures* - Parts 1 to 6 - BS 6349: 1988 British Standards Institution
- [12] *Aids to Navigation Guide* - 1990, IALA
- [13] *Guidelines for Hazard Analysis as an Aid to Management of Safe Operations* - 1992, SIGTTO - ISBN 1 85609 054 X
- [14] *A Guide to Contingency Planning for the Gas Carrier Alongside and Within Port Limits* - 1987, SIGTTO/ICS/OCIMF - ISBN 0 948691 27 1
- [15] *Design and Construction Specification for Marine Loading Arms* - 1987, OCIMF - ISBN 0 948691 28 X
- [16] *Guidelines for the Alleviation of Excessive Surge Pressures on ESD* - 1987, SIGTTO - ISBN 0 948691 40 9

Some references relating to grounding damage

- [17] *Bending and Tearing of Plate with Application to Ship Bottom Damage* - Vaughan H., Journal of Royal Institute of Naval Architects - May 1978
- [18] *Anatomy of Tanker Grounding* - Wierzbicki, et al., Marine Technology Vol 30 No. 2 - April 1993

Some references relating to collision damage

- [19] *An Analysis of Ship Collisions with Reference to Protection of Nuclear Power Plants* - Minorsky V.U, Journal of Ship Research, Vol 3, No. 2 - 1959
- [20] *Studies on Collision Protective Structures in Nuclear Powered Ships* - Akita Y., Ando N., et al, Nuclear Engineering and Design 19 - 1972
- [21] *A Method of Analysing Cargo Protection Afforded by Ship Structures in Collision and its Application to an LNG Carrier* - Kinkead A.N., United Kingdom Atomic Energy Authority, Safety and Reliability Directorate (Report SDR R 91) - 1978
- [22] *Studies of the Resistance of LNG Carriers to Collisions* - Greuner H.P., Bockenbauer M., LNG 6 Conference Proceedings - 1980
- [23] *Response of Spherical Cargo Tanks for Liquefied Natural Gas to Large Support Deformation* - Armand, J.L., Gastech Proceedings, Hamburg - 1981
- [24] *A Comparison of the Collision Resistance of Membrane Tank-type and Spherical Tank-type LNG Tankers* - Edinberg D.L. et al., Gastech Proceedings, Hamburg - 1981
- [25] *Evaluation of Ship/Ship Collision Damage using a Simplified Non-Linear Finite Element Procedure* - Valsgard S., & Jorgensen L. Det Norske Veritas, Paper Series 83. P009 - 1983
- [26] *A Proposed Method for Predicting Ship Collision Damage* - Hagiwara K., et al, International Journal of Impact Engineering - 1983

APPENDIX

LNG PORTS - RISK REDUCTION OPTIONS

General Requirements for LNG Carriers (Where figures are given they refer to LNG carriers of 135,000 m ³ capacity)	
1	The Port
1.1	Port Analysis
	Speed restrictions for LNG carriers should be appropriate to limit grounding and collision damage.
1.2	Approach Channels and Turning Basins
	Navigable depths (for most LNG carriers) should generally not be less than 13 metres below the level of chart datum.
	Under-keel clearances should be established in accordance with the sea-bed quality.
	Channel width should be about five times the beam of the ship (approximately 250 metres).
	Turning areas should have a minimum diameter of two to three times the ship's length (approximately 600 to 900 metres).
	Short approach channels are preferable to long inshore routes which carry more numerous hazards
	Traffic separation schemes should be established in approach routes covering many miles.
	Anchorage should be established at the port entrance and inshore, for the safe segregation of LNG carriers and to provide lay-by facilities in case, at the last moment, the berth proves unavailable.
1.3	Navigational Aids
	Buoys to mark the width of navigable channels should be placed at suitable intervals.
	Leading marks or lit beacons, to mark channel centrelines and to facilitate rounding channel bends, should be appropriately placed.
	Electronic navigational aids, to support navigation under adverse weather conditions, are needed in most ports.
	Lit navigational aids should be provided to allow ship movements at night.
1.4	Port Services
	Tugs should be made available and three to four are normally required giving 140 tonnes total bollard pull. (Tugs may be required to meet LNG carriers farther offshore).
	Mooring services are often required and these services should normally provide a minimum of two boats, each having at least 400 horsepower.
	Escort services comprising fast patrol craft, to clear approach channels, turning areas, jetty, etc. should be provided in busy port areas.
	Firefighting services comprising specially equipped craft, or, one or more suitably equipped tugs should be provided.

1.5	Port Procedures
	Traffic control or VTS systems should be strictly enforced to ensure safe harbour manoeuvring between the pilot boarding area and the jetty.
	Speed limits should be introduced in appropriate parts of the port approach, not only for the LNG carrier but also for other ships.
	Pilotage services should be required to provide pilots of high quality and experience. Pilot boarding areas should be at a suitable distance offshore.
	Ship movements by nearby ships, when the LNG carrier is pumping cargo, should be disallowed.
	Pilots and tugs should be immediately available in case the LNG carrier has to leave the jetty in an emergency.
1.6	Port Operating Limits
	Environmental limits for wind, waves, and visibility should be set for ship manoeuvres and these should ensure adequate safe margins are available under all operating conditions.
	Weather limits for port closure should be established.
1.7	Weather Warnings
	Forecasting for long range purposes should be provided to give warning of severe storms, such as typhoons and cyclones.
	Forecasting for short range purposes, such as those required for local storms and squalls, should be made available.
2	The Jetty
2.1	Jetty Location
	Jetty location should be remote from populated areas and should also be well removed from other marine traffic and any port activity which may cause a hazard.
	The maximum credible spill and its estimated gas-cloud range should be carefully established for the jetty area.
	River bends and narrow channels should not be considered as appropriate positions for LNG carrier jetties.
	Breakwaters should be constructed for jetty areas exposed to sea action, such as excessive waves and currents.
	Restrictions, such as low bridges, should not feature in the jetty approach.
	Ignition sources should be excluded within a predetermined radius from the jetty manifold.
2.2	Jetty Layout
	Mooring dolphin spacing - between the outermost dolphins - should not be less than the ship's length (approximately 290 metres).
	Mooring dolphins should be situated about 50 metres inshore from the berthing face.
	Mooring points should be suitably positioned, and have suitable strength, for the environmental conditions.
	Quick-release hooks should be provided at all mooring points.

	Breasting dolphin spacing should be designed to ensure that the parallel body of the ship is properly supported.
	Fendering for the dolphins, and for the berth face, should be to a suitable standard.
2.3	Jetty Equipment
	Pipelines and pumps etc should be designed to provide a rapid port turn-round.
	Emergency Release Systems at the hard arms should be fitted in accordance with industry specifications. The ERS should be suited to both ship and shore by interlinking and a PERC should be fitted to each hard arm for emergency stoppage and quick release purposes.
	Emergency shut-down valves should be fitted to both ship and shore pipelines and should form part of the ERS system.
	Powered emergency release couplings (PERCs) with flanking quick-acting valves should be fitted to the hard arm as part of the ERS system.
	Plugs both on ship and shore to carry all ESD and communication signals should be standardised.
	Surge pressure control should be provided in LNG pipelines.
	Communications equipment (telephone, hot-line and radios) should be provided for ship/shore use.
	Load monitors, to show the mooring force in each mooring line, should be fitted to quick release hooks.
	Gangways should be provided to give safe emergency access to or from the ship.
2.4	Basic Firefighting Facilities
	Water curtain pumps and pipelines should be provided.
	Fixed Dry Powder systems should be provided.
	Gas detection monitors should be fitted at strategic locations.
	Fireproof material should be used for the construction of hard arms (no aluminium).
2.5	Jetty Procedures
	On shore jetty safety zones should be effectively policed while the ship is alongside thus providing control over visitors and vehicles.
	Offshore safety zones should be effectively policed by a guard boat to limit the approach of small craft.
	Passing ships, close to the jetty, should have their speed controlled by the harbour VTS system.
	Communications procedures should be well established and tested.
	Contingency plans should be available in written form.
	Operating procedures should be available in written form.
	A Port Information/Regulation Booklet should be provided for passing operational advice to the ship.